

---

# ICP2432 Hardware Installation Guide

## Hardware Installation

---

### Caution

The ICP2432 board contains integrated circuits that are sensitive to electrostatic discharge (static electricity). When handling the ICP2432 outside its protective bag, always wear an antistatic wrist strap or take an equivalent grounding precaution.

---

1. Remove the packing list and check it against the items shipped to ensure that you have received the correct board, cables, and optional items.
2. Remove the ICP2432 board from its antistatic bag and inspect it for shipping damage, then place it on the bag, component side up.
3. Record the board's serial number (from the barcode label) in your equipment log.
4. Turn off the power to the system and remove the cover.
5. Remove the slot cover from the selected PCI bus slot.
6. Slide the ICP2432 into the PCI connector. Be very careful not to scrape adjacent boards or use undue force. Align the rounded notch in the retaining bracket with the hole in the frame.
7. Screw the retaining bracket to the frame before installing the cable. Insert a screw, but push the notch against the screw before tightening. Otherwise the bracket may interfere with the bracket of an adjacent slot cover or with another board.
8. Connect the cable(s).
9. Replace the cover and turn on power to the system. After 10 seconds, the LEDs visible in the I/O slot should be constant green and blinking red. You are now ready to install the software.

## Electrical Interface

The ICP2432 is a DTE device. All cables and connectors are implemented according to the EIA specifications for DTE devices.

The two-port and four-port versions of the ICP2432 use a multiprotocol line driver/receiver. This part supports electrical interface selection under program control. The software configuration that is downloaded to the card determines the EIA interface selection for each port.

The I/O cable for the two-port and four-port boards uses the EIA-449 (DB37) or EIA-530 (25-pin) pinouts as specified in those standards. [Figure 1](#) shows the signal mapping for the EIA-449 interface. [Figure 2](#) shows the signal mapping for the EIA-530 interface (which is also used for EIA-562 and EIA-232).

The eight-port version of the ICP2432 always provides an EIA-232 electrical interface on all ports. [Figure 3](#) shows the signal mapping for the EIA-232 interface.

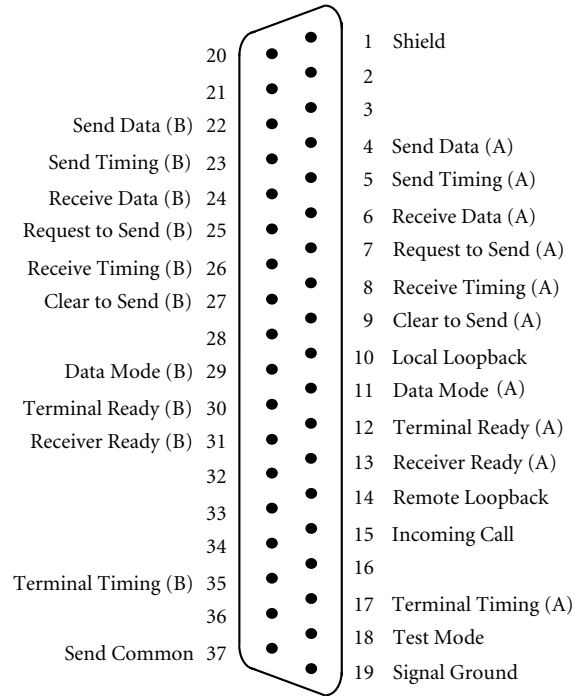

3295

**Figure 1:** Signal Mapping for the 37-pin EIA-449 Interface

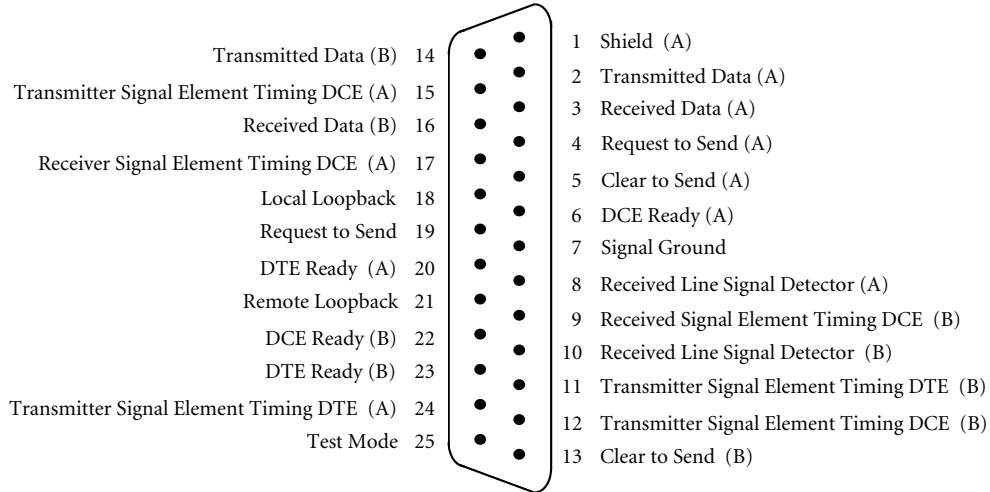

3294

**Figure 2:** Signal Mapping for the 25-pin EIA-530 Interface

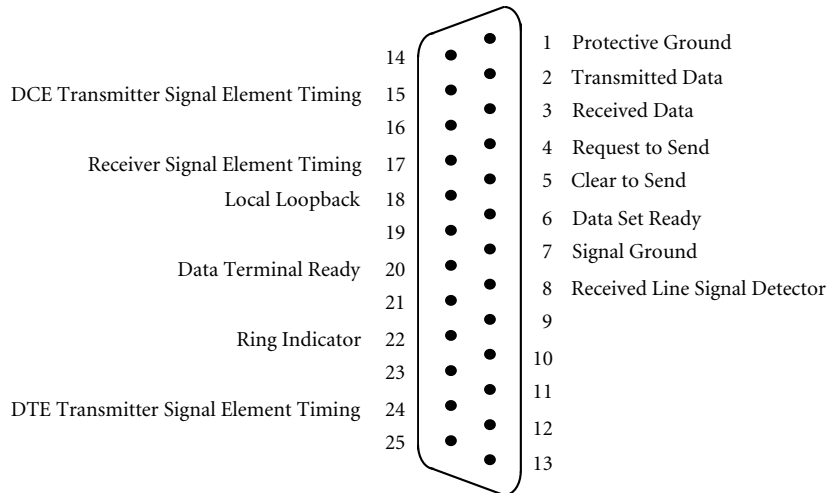

3293

**Figure 3:** Signal Mapping for the 25-pin EIA-232 Interface